

Raum4000b Battery Charger

Installation and Owner's Manual

Raum Energy Inc. Proprietary 2010



IMPORTANT SAFETY INSTRUCTIONS

SAVE THESE INSTRUCTIONS - This manual contains important instructions that shall be followed during installation, operation and maintenance of the Raum4000b Battery Charger.

Understand These Symbols

The following important symbols are used on the battery charger and in this manual and are accompanied by **risks of injury or death** if ignored or improperly understood:



CAUTION – Risk of Electric Shock.



CAUTION – Hot. Burn Risk.



Important Personal and Equipment Safety Information.



CAUTION – Risk of fire.



Equipment-Grounding Terminal (Earth Ground).



An electrical connection bonded to the Equipment-Grounding terminal (Earth Ground).



Alternating Current Supply (a grid connection).



Direct Current Supply (a battery or photovoltaic connection).



Phase (a wind generator connection).

Remember These Rules



WARNING – The following rules contain important information to keep you and your equipment safe.

1. The Raum4000b must be installed by a skilled and qualified party.
2. The installation procedure must be in strict accordance with this manual and with national and local health and safety regulations as they apply.
3. Do not install the battery charger if there are signs of damage or you have reason to suspect damage (following a drop, a blow, suspect shipping and handling, loose and rattling components, etc.). Contact your dealer instead.
4. Risk of Fire: Adhere strictly to the clearance rules and ambient temperature requirements that this manual recommends when selecting an installation location. Do not otherwise cover the battery charger or obstruct ventilation in any way.
5. Risk of Fire and Electric Shock: Use wiring, conduits and fittings that have at least the minimum electrical and environmental ratings as specified by this manual and are compliant with the national electrical codes and local regulations responsible for your location.
6. Risk of Fire: Output over-current protection is 210 amperes. To provide added safety against the risk of fire it is recommended that additional external over-current protection be added between the battery charger and the batteries. Connect only to a circuit provided with a minimum of 180 amperes over-current protection in accordance with the NEC / CEC, ANSI/NFPA 70 (in the USA/Canada) or equivalent national codes and local standards (in other countries).
7. Risk of Burning: Exterior parts of the battery charger such as the heat sink may get hot under abnormal conditions.
8. Never disassemble or modify the Raum4000b. There are no user serviceable parts inside.

More Helpful Information

Acronyms to Note

| | |
|------|---------------------------------------|
| AC | Alternating Current |
| ANSI | American National Standards Institute |
| CSA | Canadian Standards Association |
| CEC | Canadian Electrical Code |
| DC | Direct Current |
| DNS | Domain Name System |
| EMI | Electromagnetic Interference |
| GFDI | Ground Fault Detector-Interrupter |
| HV | High Voltage |
| LAN | Local Area Network |
| LED | Light Emitting Diode |
| NEC | National Electrical Code |
| NFPA | National Fire Protection Association |
| OLED | Organic Light Emitting Diode |
| PMG | Permanent Magnet Generator |
| PIN | Personal Identification Number |
| POI | Period of Interest |
| PV | Photovoltaic |
| UI | User Interface |
| UL | Underwriters Laboratories |
| WAN | Wide Area Network |

Who to Contact

Your safety is important. Please acquaint yourself with the important safety instructions above and read the rest of the manual very carefully before commissioning your renewable energy system. Identify WARNING and CAUTION labels on the equipment. If at any time you discover equipment damage, suspect a faulty install, or are experiencing abnormal system behaviour as defined in the Troubleshooting section, please start by contacting your dealer. To help identify potential Warranty issues, please take the time to complete this table with shipping details, installation details as well as important contact information:

| | |
|---|---|
| Dealer: | Shipper: Date Delivered: Delivery Condition: |
| Utility Company: Inspector: Inspection date: | Installer: Date Installed: |
| Notes: Serial Number: Part Number: Manufacturing date: | Manufacturer: Raum Energy Inc. www.RaumEnergy.com 1-306-651-0586 |

Table of Contents

- Introduction7**
 - The Purpose of a Battery Charger 7
 - Features at a Glance 8
 - The Battery Charger Up Close 10
- Installation 11**
 - Preparation 11
 - Mounting the Battery charger 17
 - Wiring the Battery charger 19
 - Enabling the Battery charger 23
- Interaction..... 24**
 - Front Panel Interface 24
 - Web Interface 32
 - USB Interface 35
 - Generator Brake.....36
- Maintenance 37**
 - General..... 37
 - Firmware Upgrades..... 37
- Troubleshooting 38**
 - How the 4000i Handles Faults 38
 - Q&A..... 39
 - Customer Service 40
 - Warranty Information..... 40
- Appendix A: Technical Description..... 41**
- Appendix B: Raum4000b Unit Ratings..... 42**
- Appendix C: Battery Charge States..... 43**

Introduction

The Purpose of a Battery Charger

Wind is an uncontrolled and wildly varying power source. Small scale wind generators convert this wild wind power into either AC or DC electricity. The Raum4000b Battery Charger is designed to condition and dispatch power from a wind generator to a battery bank such that the turbine energy becomes useful to the end user (See Figure 1).

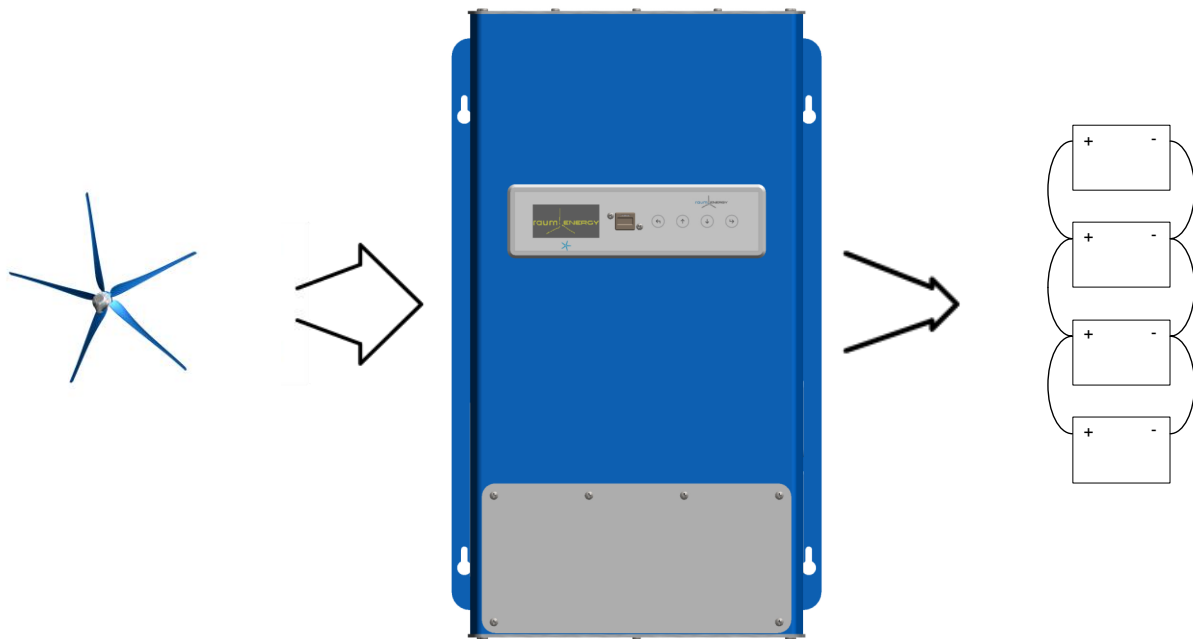

Figure 1 - Wind to battery bank energy conversion process

Features at a Glance

Superb Efficiency

The Raum4000b features state of the art silicon and magnetic technologies that enable peak efficiencies over 95%¹. Rest assured knowing that your new battery charger competes with the best in world.

Organic LED Display

The Raum4000b is the first battery charger in its class to feature OLED technology. A big, bright OLED screen on the user interface (UI) panel provides superior efficiency, excellent daylight visibility and a fast response even in cold temperatures where a traditional back-lit LCD would be unreadable.

Internet Ready

A standard Raum4000b battery charger comes with a built-in web server that allows secure internet access to all its performance parameters and system health indicators.

Data Analysis

In addition to direct internet access, a front face USB port allows you to download data on-site using a regular USB thumb drive. Choose from a variety of data parameters to include.

Field Upgradeable

Firmware upgrades may be made available from time to time. The battery charger firmware can be upgraded via the internet or a USB thumb drive.

Wind Generator Compatibility

The Raum4000b has hardware compatible with 3-phase wind generators up to 4 kW. No external power preconditioning is required. The battery charger has versatile load line programmability and can control an external generator brake.

¹ When compared to solar battery chargers that do not require a rectification stage, the Raum4000b has a peak efficiency of over 96%!

Solar Compatibility

The Raum4000b battery charger can connect to a string of PV panels instead of a wind generator. Please visit www.RaumEnergy.com for PV string sizing recommendations.

Parallel Operation

Raum4000b battery chargers can be easily teamed up to handle larger PV or wind configurations.

Passive Cooling

Long term mechanical reliability is boosted by fan-free operation.

The Battery Charger up Close

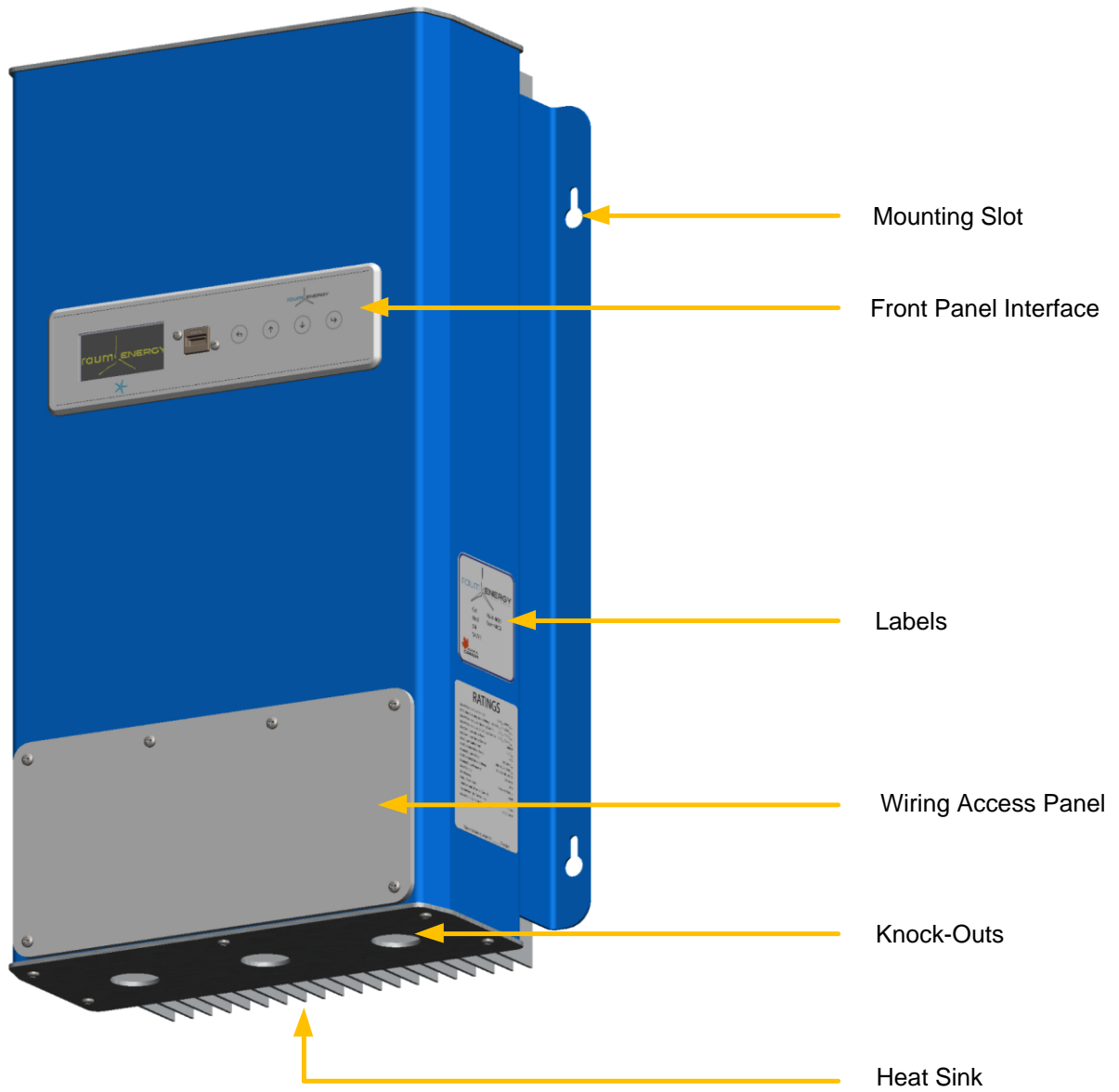

Figure 2 - Physical Features of the Raum4000b

Installation

Preparation

Power Sources

- The Raum4000b cannot be connected to a wind generator and a PV string at the same time. It is specifically preconfigured to accept either a specific wind generator model or an appropriately sized PV string.
- The Raum4000b is preconfigured for a specific battery voltage, which is field selectable as either 24V or 48V (nominal battery voltage). Battery voltages other than the two specified above may cause damage to the unit.

Permits

- In the case where the battery charger is part of a system that interacts with a utility grid it is the owner's responsibility to apply for any necessary electrical permit(s) from the utility company and/or governing body having authority over grid-interactive installations in your area. Such permits are legally required before the installation. Your Raum Energy dealer will be able to point you in the right direction.

Codes

- It is the owner's responsibility to ensure that the battery charger installation is compliant with local and national electrical codes as they apply to electrical equipment, wiring, conduits, fittings and their installation. The installer must be qualified in this respect.

Environment

- The Raum4000b battery charger has a NEMA 4 (watertight) enclosure. It may be installed indoors or outdoors where local electrical codes permit.
- The battery charger should be mounted in a well-ventilated location with a normal ambient temperature range of -40 to +40 °C (-40 to 140 F).

- If installing outdoors, we highly recommend a permanently shaded location. Cooling the battery charger will help maximize power since thermal throttling modes kick in above 40 °C (104 F).
- Shield the location from debris where possible. Leaves, nests, cob webs, etc. that accumulate on the battery charger may interfere with the heat sink ventilation and reduce performance.
- If installing indoors, select a wall that is insulated from the outside when it itself is a target of direct sun light. If installing in the Northern hemisphere try to avoid a Southern wall installation, likewise if installing in the Southern hemisphere, try to avoid a Northern wall installation.

Positioning

- The battery charger should be installed at eye height.
- The location must allow easy access for maintenance and installation.
- The battery charger must be installed vertically and in the upright position only. Installation in any other orientation may result in reduced performance.

Mounting

- Ensure that the surface and wall composition chosen for mounting the battery charger is capable of supporting 60 kg (132 lb).
- The keyhole slots on the battery charger are provided for the purpose of mounting and require No. 10 (4.83 mm) screws or bolts. Choose wall anchors and screws that are designed for the particular wall composition, environment and weight of the battery charger.
- With drywall (gypsum wallboard), always provide additional support for the battery charger. One way to achieve this is to mount the battery charger to ½” plywood which is secured to the wall at stud locations.

Clearance

- Apply the following clearance rules when mounting the battery charger to achieve good ventilation and performance:

| | |
|---------------------|--------------|
| ↕ Above and Below | 300 mm (12") |
| ↔ To Left and Right | 25 mm (1") |

- Ground clearance for an outside installation is at least 1 m (39 “)
- Larger clearances may be required in hotter environments
- For multiple battery charger installations, a staggered mounting configuration is recommended so that the heat from units below does not cause power de-rating on the units above.

Hardware

- Be sure to use only electrical hardware: conduit, conduit fittings, wire, junction boxes, and switches that are listed and approved by the appropriate regulatory agencies and are compliant with your national and local electrical codes as they apply.
- To maintain the environmental rating of the battery charger use only watertight electrical hardware and watertight wiring methods as outlined by the codes above.
- Additional details about electrical hardware can be found in the generator installation manual and the wiring section in this chapter.
- Due to different wall mounting requirements for different locations no mounting hardware is supplied with this battery charger.

Dimensions

- The wiring compartment on the battery charger features trade size 21 (US $\frac{3}{4}$) knockouts on the bottom for feeding power connections from the generator and utility panel as well as communication lines. These knockouts are compatible with listed watertight conduit fittings. Actual dimensions are shown in Figure 3.
- Do not drill any additional holes in the wiring compartment. This will not only void the warranty but also compromise the environmental rating of the enclosure.
- The physical dimensions of the battery charger are given in Figure 3.

Raum4000b Battery Charger Manual

v. 1.8

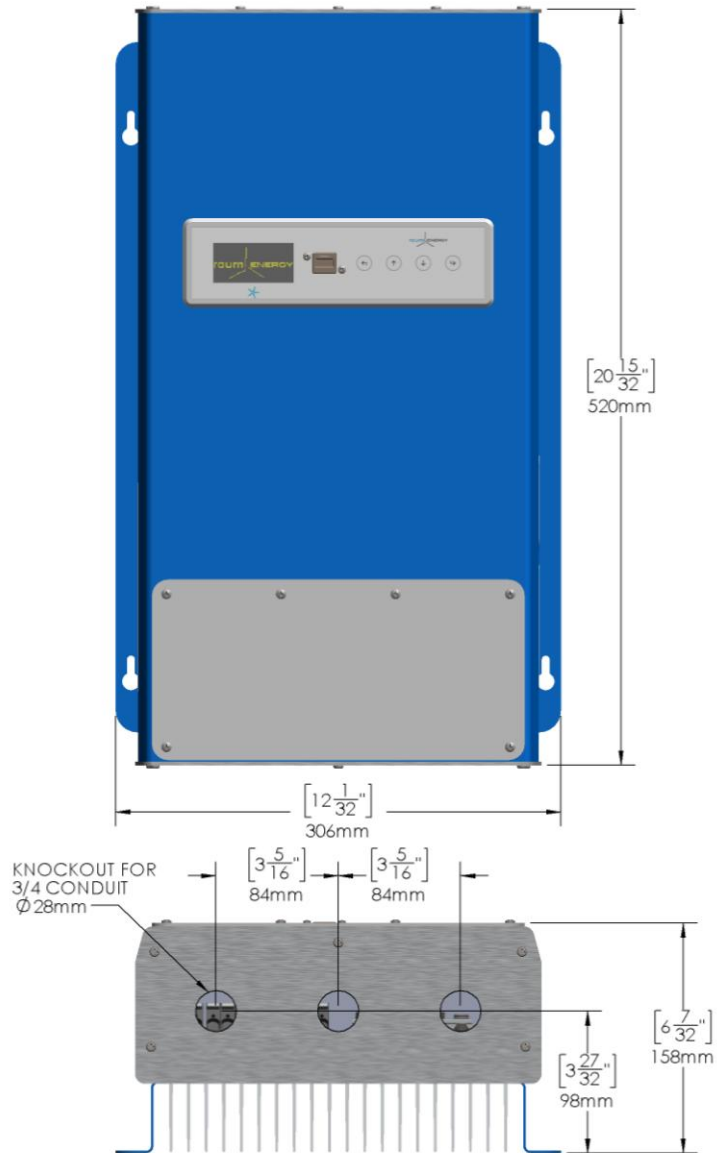

Figure 3 - Raum4000b Dimensions

Wiring Distances

- The distance between the battery charger and batteries, as well as the battery charger and generator must be minimized to reduce power losses in the lines connecting them. The minimum gauge of wire to use for each battery terminal connection is either a single 2 AWG (diameter = 6.54 mm) conductor or 2 parallel 5 AWG (diameter = 4.62 mm) conductors. Use the graph in Figure 4 to determine the expected losses for a given distance between battery charger and battery bank for a given wire gauge. For specifics on generator to battery charger line losses please consult the generator installation guide. **It is important that the appropriate wire gauge is selected for minimal line loss from battery charger to battery bank, allowing for accurate battery bank voltage measurements. Inaccurate voltage measurements may cause abnormal behaviour of the charging algorithms and/or damage to the battery bank.**
- For Internet connectivity keep in mind that standard CAT-5 cable is limited to 100 m. Additional network hardware may be required. Please consult a computer network professional about your particular situation.

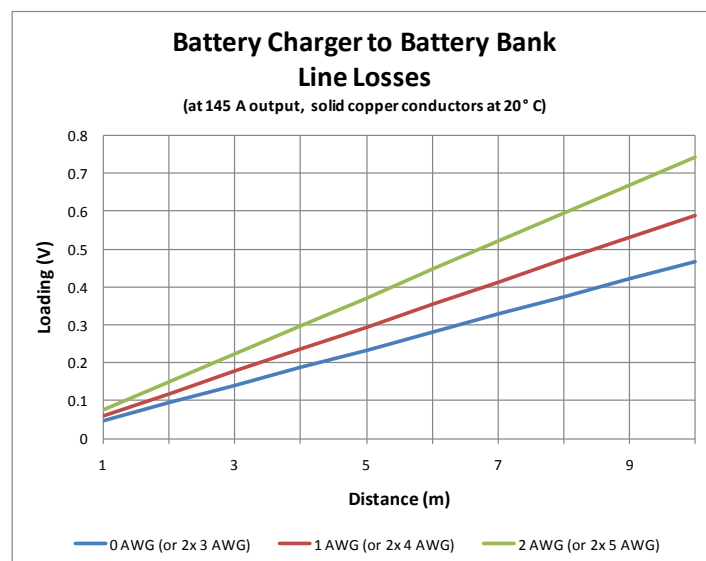

Figure 4 - Line Losses

Mounting the Battery Charger



CAUTION – Risk of Electric Shock and Fire. Do not drill or screw into walls where electrical circuits and plumbing within can be damaged in the process.

1. On the installation surface, mark the 4 locations of the mounting holes using either the dimensions in Figure 5 as your guide. Ensure the marks are level.
2. Drill out the marked locations according to the requirements of the wall anchors. Insert the wall anchors according to their instructions.
3. Drive the screws most of the way into these anchors. Ensure that they are secure. Carefully hang the battery charger onto this framework. Check that all keyhole slots are filled by the screw body.
4. Drive the screws the rest of the way so that the battery charger is clamped flush to the wall by the screw heads. Only use driving torques rated for the screw and wall anchor type.

Raum4000b Battery Charger Manual

v. 1.8

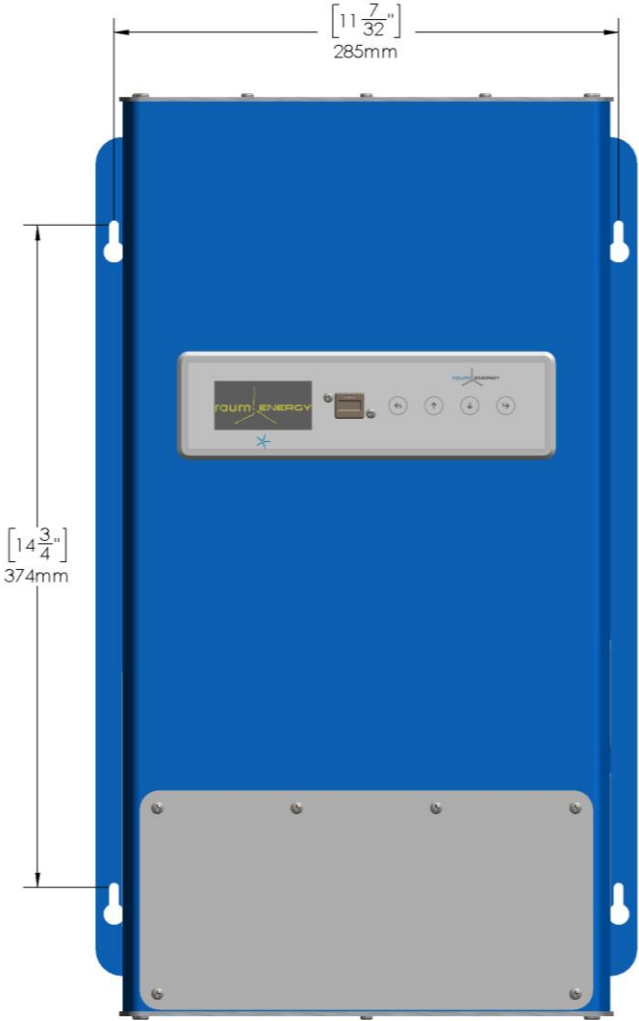

Figure 5 - Mounting dimensions

Wiring the Battery Charger



CAUTION – Risk of Electric Shock from energy stored in capacitors. Do not remove cover panel until 5 minutes after disconnecting all sources of power.



CAUTION – Risk of Fire. When designing the generator-battery charger interface, wire gauges and types must be rated for the maximum 3-phase input voltage and maximum 3-phase input current as per the Unit Ratings (See Appendix B: Raum4000b Unit Ratings)

Maximum 3-phase input voltage: $450 V_{rms}$ (line to line)

Maximum 3-phase input current: $15.6 A_{rms}$



CAUTION – Risk of Fire. Incorrect wiring of the battery bank may cause dangerous short circuit conditions that may result in fire.



CAUTION – Risk of Electric Shock. Ensure that generator brake is on. The generator must not be spinning whatsoever when connections are made to the battery charger. A spinning generator means dangerous voltages are present on the 3-phase connection.



Ensure the battery charger is firmly mounted to the wall before making electrical connections



The battery charger maximum environmental rating is NEMA 4: watertight / IP65. To ensure this rating is maintained, make all connections using only conduit, conduit fittings, other wiring components and wiring methods that have this rating or better.



The installation must comply with electrical codes that have jurisdiction at the installation locale. This applies to wiring methods, conduit, conduit fittings, wire size and wire performance (90°C). A DC disconnect with a minimum rating of 80V and 180A will be required between the battery charger and the battery bank.



It is the installer's responsibility to provide mechanical strain relief for all connections. Only use code-approved knock-out fittings that include strain relief mechanisms.

1. The basic connection requirements of a typical Raum4000b installation are shown in Figure 6. Other details such as the placement of a net meter and additional disconnects are not shown.
2. Wire connections are to be completed as instructed by Figure 6 and Figure 7. Strip the 3-phase wires from the generator, the generator brake wires and the grid AC wires back 12-13 mm (1/2 inch), and feed these wires through the left side port on the underside of the Raum4000b battery charger. Similarly, the battery cables (both positive and negative) will need to be stripped back 12-13 mm (1/2 inch) and fed through the right side port on the underside of the Raum4000b battery charger.



This unit is outfitted with thumb lever connection terminals which do not require tools to operate. These terminals do require a firm lifting force to open the spring clamps. Personal care must be taken when releasing the levers as they may snap back with some force.

3. The generator and brake connections are made by lifting the spring loaded thumb lever of the terminal, inserting the wire into the terminal hole and releasing the lever. The lever will snap back in place to clamp the wire. Verify that the connection is secure and made to the copper of the conductor and not the insulation. (Wire stripping length requirement: 12-13 mm (1/2 inch)).
4. The battery terminal connections are made by inserting the wire end into one of the ports on the appropriate terminal block and securing the wire down with a 4.5 mm (3/16" – actual metric size 4.76 mm) hex-end torque driver. Torque specification for battery terminal connections is 8.5 N·m (75 in·lbs). It is recommended that an anti-corrosion compound is applied to all battery terminals and battery cables before the connections are made.
5. An optional Ethernet connection may be made for internet connectivity. An RJ-45 port is provided and requires a standard modular RJ-45 connector terminated to CAT-5 cable (or better). Pre-terminated cables for this purpose are commonly available at computer stores. A removable watertight Ethernet connection can be made at the knock-out by using an IP67 RJ-45 connection system such as offered by Conec: (<http://www.conecspec.com>).

Raum4000b Battery Charger Manual

v. 1.8

- Once all connections have been made, replace the front panel ensuring the O-ring reseals correctly.

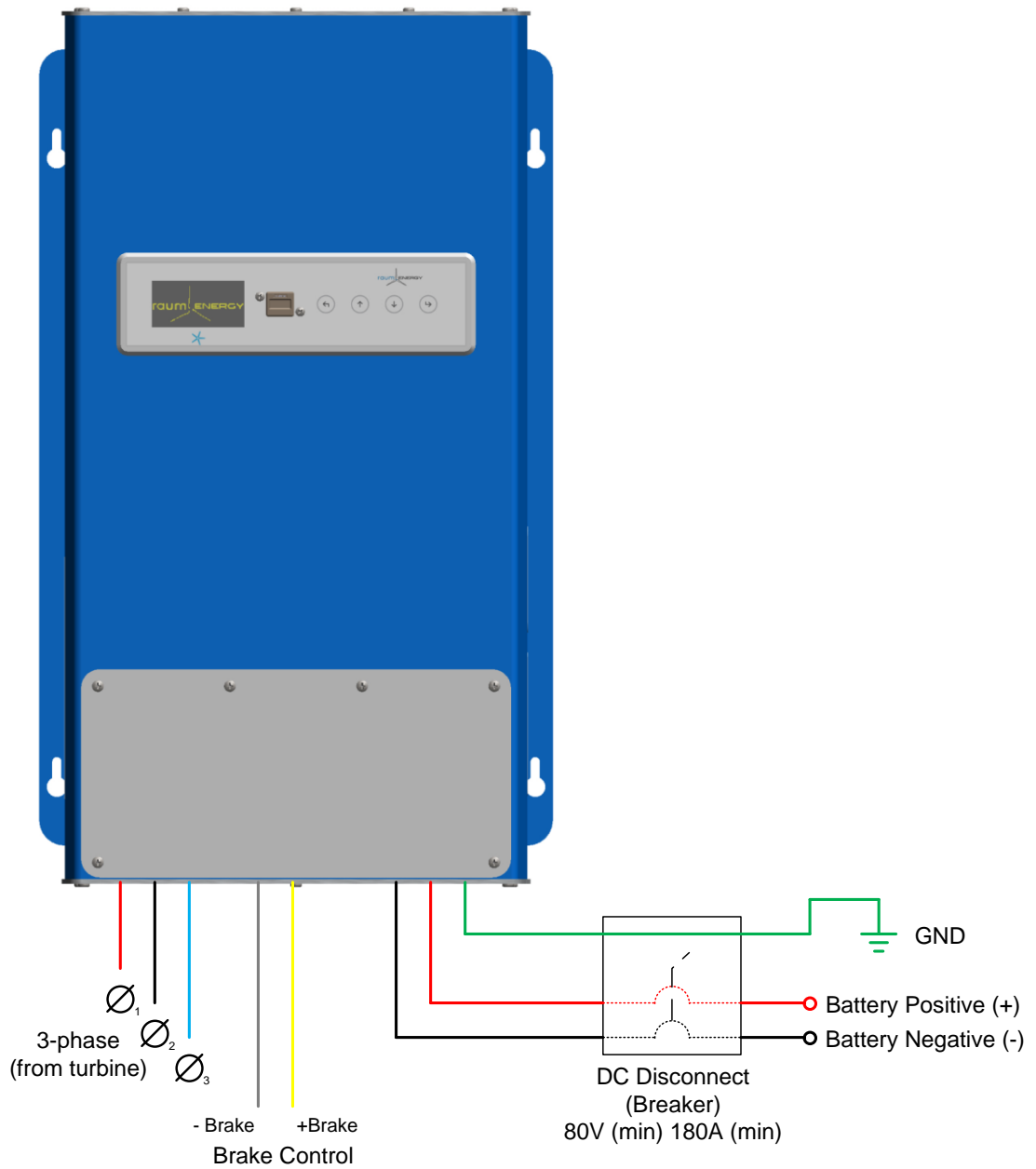

Figure 6 – Wiring setup of the Raum4000b system

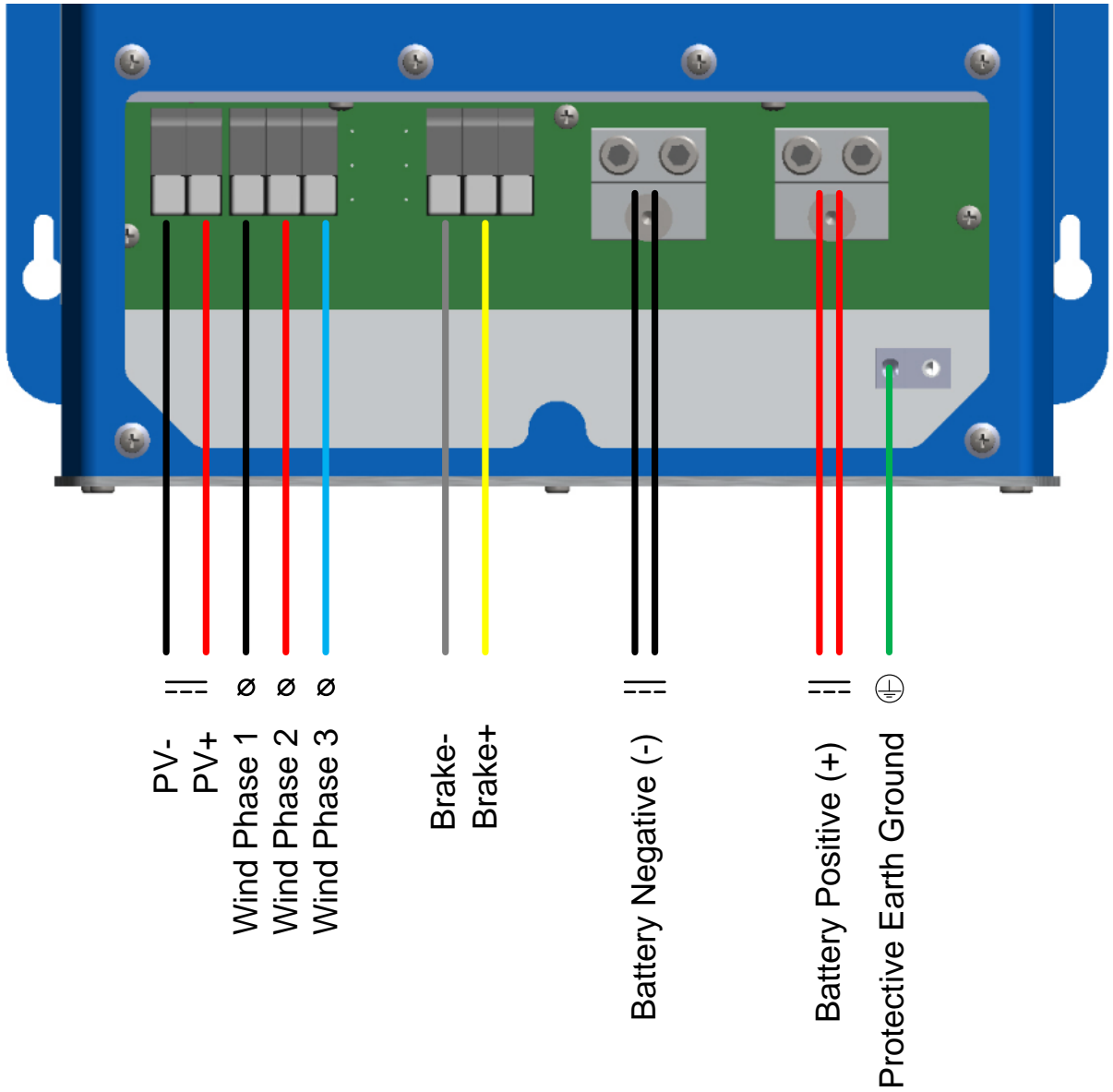

Figure 7 - Connection details for the Raum4000b. Important: Wind and PV are not permitted at the same time.



WARNING – Never disconnect the battery charger from the batteries when the turbine is spinning. Always ensure the turbine brake is enabled and the turbine has stopped before disconnecting the battery charger from the batteries. Failure to do so will result in damage to the battery charger.

Enabling the Battery charger

1. Flip the battery disconnect switch to the connected position.
2. If there is a manual generator brake, flip it to the off position.

What to Expect

Once the battery charger's battery power is turned on the Raum4000b battery charger will perform a self check of its systems and then await the wind (or sun depending on the installation). The default battery system voltage is 24 V nominal. If the system voltage for a particular installation is something other than the default 24 V nominal proceed to the Advanced Menu section of the manual (page 30) for further information on setting the system voltage. When completed the battery charger will engage the energy source and proceed to export power. If the wind picks up again after having died down the battery charger resumes exporting immediately.

Interaction

Front Panel Interface

The front panel interface is depicted in Figure 8 and consists of a graphical OLED display, a USB port, a blue Producing indicator, a yellow Error indicator, a red Ground Fault indicator and four buttons for menu navigation.

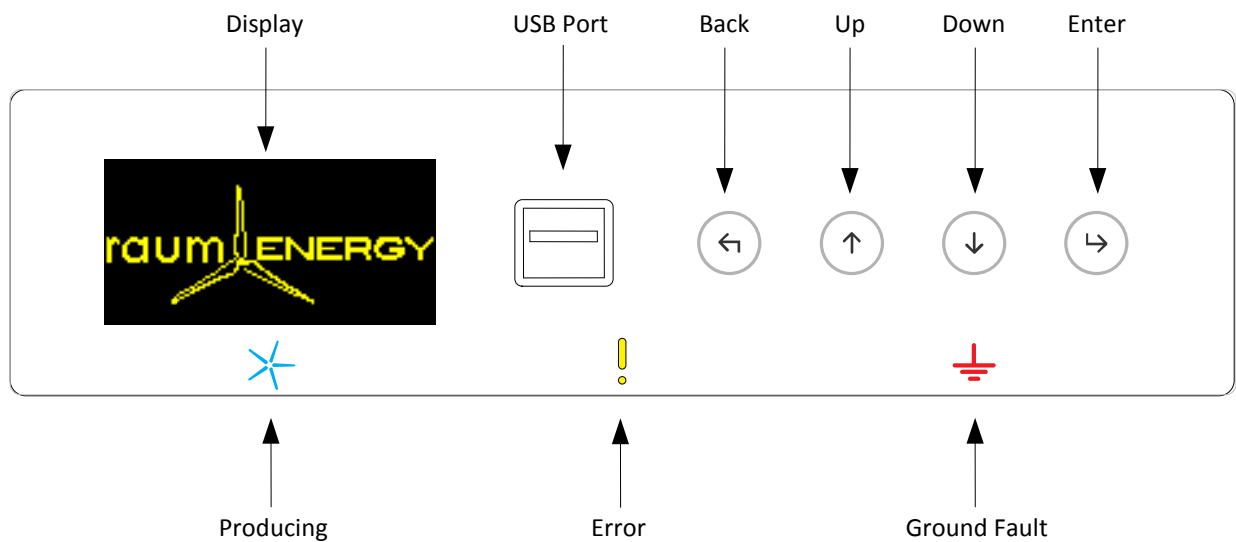

Figure 8 - Front Panel Interface

Indicator Modes

The blue, yellow and red indicators will only appear when lit. Different modes of operation will cause different indicators to light up or blink.



Start up



Waiting for Wind



Producing Power



System Error



Ground fault detected and isolated – Applicable to Raum4000i only

Menu Navigation

Navigating the menu system is done using the front panel buttons:



Escape to the previous menu



Move to the previous submenu option



Move to the next submenu option



Enter the submenu

Changing Settings

The same buttons are also used to adjust system settings:



Deselect value to change / Undo Changes



Adjust value higher



Adjust value lower



Select value to change / Apply changes

Home Screen

After a period of inactivity, or when Home is selected in the main menu, the Raum4000b battery charger display reverts to a default home screen (e.g. Figure 9).

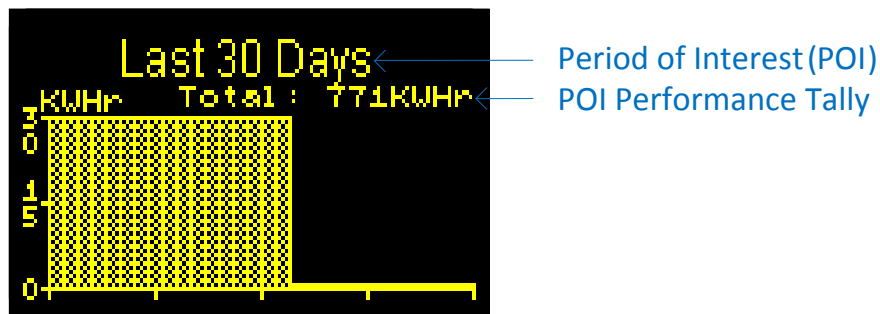

Figure 9 - Home Screen Example

Information on the home screen tallies the performance of the system over a selectable period of interest (POI). The Home Screen can be used to view real-time or historical performance data in the form of a graph of power/energy over time. For the first 10 seconds, the graph heading displays the selected POI and the subheading displays the total export during that period. After 10 seconds, the heading reverts to displaying the battery charger status (e.g. 'Exporting 3240W') while the subheading displays the selected POI.

Available real-time POI time scales are Last Minute, Last Hour, Last 24 Hours, Last 30 Days, and Last 12 Months. To select a different real-time POI time scale use the Up (↑) or Down (↓) buttons. In real-time view mode, the rightmost data on the graph represents the current instant. For example, in Last 12 Months view, the rightmost bar is the current month, with past months appearing to the left.

Available historical time scales are Day, Month, and Year, and are labelled with the respective date, month, or year. The historical POI modes are entered by selecting the corresponding real-time mode and pressing the Enter button (↵). For example, to browse through past performance one day at a time:

1. From the default home screen (real-time mode), use the Up (↑) or Down (↓) buttons to select the Last 24 Hours POI mode.
2. Press the Enter button (↵) to enter historical mode browsing by day.
3. Use the Up (↑) or Down (↓) buttons to browse through previous days' performance. The leftmost bar of the graph represents export between 12:00AM and 1:00AM, with the rightmost bar represents export between 11:00PM and 12:00AM.
4. When finished in historical mode, press the Back button (⏪) to return to real-time Last 24 Hours mode.

A similar procedure is used to browse the Month and Year historical modes, which are available by pressing the Enter button (↵) while in the Last Month and Last Year modes, respectively.

Main Menu

The Main Menu provides access to battery charger setup, performance history and system health information. Press the Back button (⏪) to access the Main Menu from the Home Screen. A view of the Main Menu is shown and commented on below.



- Home – Use this to return to the home screen from the Main Menu. By default, after 60 seconds of inactivity, the display will return to the home screen, display current energy export and battery charger status.
- System Levels – Use this to view turbine, and battery operational levels (the options contained in this section are further described in the System Levels section on page 29).
- Status – Use this to view the current battery charger status. This status is

also displayed on the home screen after 10 seconds. It displays the current export power if the system is operating, and includes an indication of any errors encountered by the battery charger if it is not exporting.

- Clock – Use this to view or set the clock on the battery charger. The clock is used for data logging purposes, so be sure to set it for your time zone once your unit is set up.
- Serial Number – Use this to retrieve the serial number of your unit.
- Advanced – Use this to browse the Advanced Menu, described below, which contains advanced configuration options for the battery charger.

System Levels

The System Levels menu displays all available real time performance variables of the installation.

| | |
|---------------|---|
| Power Out | Instantaneous output power of the battery charger |
| Battery Volts | Measured battery bank voltage |
| Battery State | Current charge state of the battery charger |
| Output Amps | Measured output current of the battery charger |
| Turbine RPM | Revolutions per minute of the wind generator |

For a sense of the normal operational values for the variables listed in the table above refer to Appendix B: Raum4000b Unit Ratings.

Advanced Menu

A view of the Advanced Menu is shown and commented on below.

```
Advanced
Batt Config:
Network Name
Generator Health
Software Update
Service Code
Internal Menu
Load Line
```

- Batt Config – Use this menu option to configure specific settings for system voltage and battery charge states (the options contained in this menu are further described in the Batt Config section on page 31).
- Network Name – Use this menu to choose between the default network name ('Raum4000b') and one that includes your device's serial number for differentiation from other units on the network.
- Generator Health – Use this to disable generator health monitoring. (For solar operation or operation using a non-standard turbine.)
- Software Update – Use this to search the USB memory stick for a firmware update.
- Service Code – Use this to enter the unit's service code, allowing service by qualified personnel.
- Internal Menu – Use this menu for advanced configuration or troubleshooting of the Raum4000b. The options contained in this menu are only available when the appropriate service code is entered (service codes will only be provided to authorized

Raum Energy dealers and distributors).

- Load Line – Use this to view the load line of the Raum3.5kW turbine.

Batt Config

The Batt Config menu contains settable options for the battery system voltage and battery states. Each of the menu options are described below.

| | |
|----------------|--|
| Batt Voltage | Battery system voltage which is settable as 24V or 48V – default setting is 24V. |
| Float Voltage | System float voltage – default setting is 27.20V. |
| Absorb Voltage | System absorb voltage – default setting is 28.80V. |
| Absorb Start V | Voltage setting that automatically initializes a new absorb cycle – default setting is 26.00V. |
| AbsEnd Current | The current setting to trigger the end of an absorb cycle – default setting is 10.00A. |
| Abs End Delay | Amount of time the current must stay below the AbsEnd Current setting before the absorb cycle is finished – default setting is 5.00 minutes. |

For a more detailed description of battery charge states and the Batt Config settings refer to Appendix C: Battery Charge States.

Web Interface

If an internet connection is present, a user may monitor the system performance through a web browser. Features of the web interface are continually being upgraded, so check back at Raum Energy's website for new firmware updates.

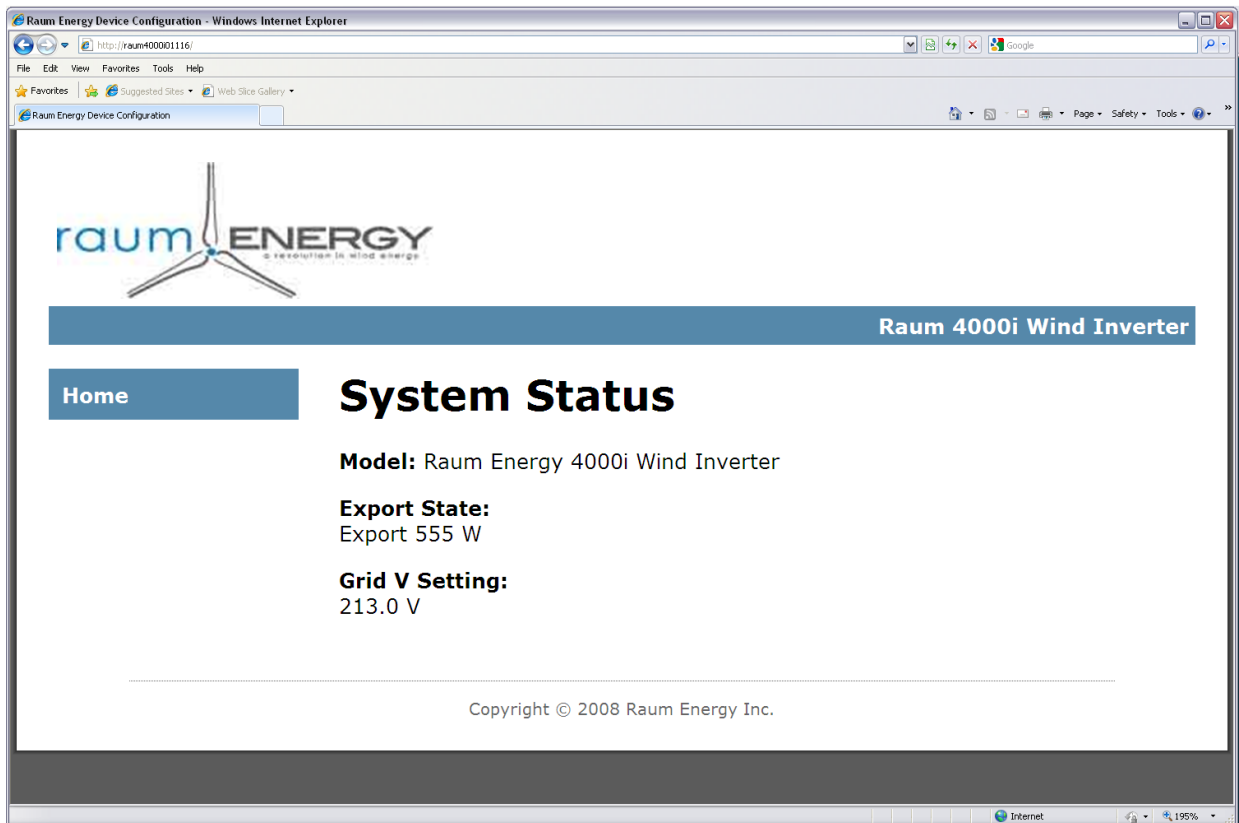

Figure 10 – The Raum4000b Home Page

Network Setup

In order to gain access to the Web Interface, the Raum4000b must be integrated into an IP network. The following section is targeted towards a person with experience in setting up IP networks. The external configuration of gateways, routers and other nodes of a typical network are manufacturer and installation dependent and outside the scope of this

manual. Knowledge of port forwarding may be required to gain public access. Depending on the network infrastructure, an IT professional may need to be consulted to complete the network setup correctly and securely. Some typical connection types are now described.

Direct Connection

A direct connection can be established by making an Ethernet connection between the battery charger and a computer as in Figure 11. To access the web interface, direct a web browser to the battery charger name as set in the Advanced → Network Name submenu. This menu allows selection of either the default name or a name based on the battery charger's serial number allowing the coexistence of multiple battery chargers at a given site. For instance, if the battery charger name is Raum4000b, go to <http://Raum4000b> in a web browser.

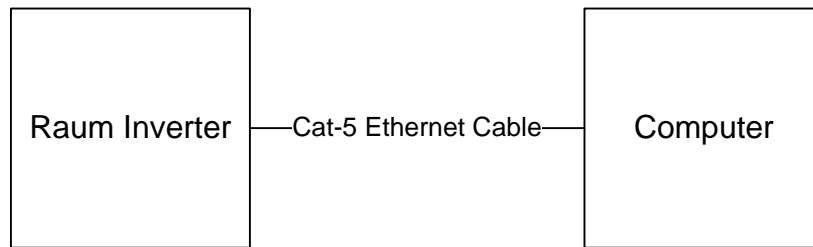

Figure 11 - Direct Connection

LAN Connection

A LAN connection can be established by adding the Raum battery charger to a local area network through a router or switch as you would a computer. Port forwarding of port 80 must be set up on the router/switch to point to the IP address of the battery charger.

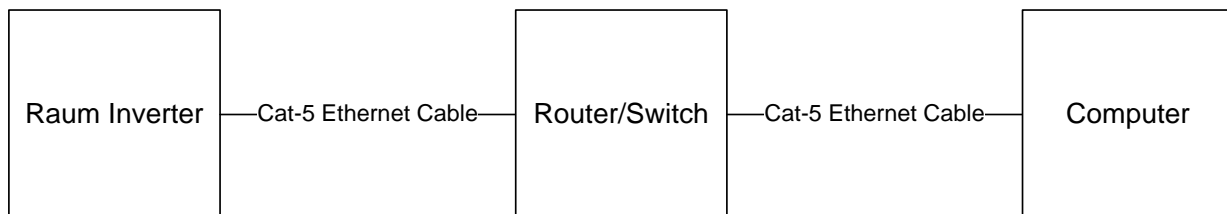

Figure 12 - LAN Connection

WAN Connection

A WAN connection can be established by adding the Raum Battery charger to a wide area network through a gateway (such as a router-modem combination) as you would a computer. Port forwarding of port 80 must be set up on the gateway to point to the IP address of the battery charger. A dynamic DNS service such as that provided by <http://www.dyndns.org> will have to be employed when dynamic IP addresses are involved on the battery charger-gateway side.



Figure 13 - WAN Connection

Remote Access WAN Connection

A Remote Access WAN connection is simply a WAN connection where the battery charger-side Gateway-internet connection is wireless such as radio, cellular, or satellite. This type of connection is typical for remote locations without wired internet service. Additional network implications may exist over and above those of a wired WAN Connection. Permission, Gateway recommendations and setup may be required from the wireless internet service provider.



Figure 14 - Remote Access WAN Connection

USB Interface

The USB interface can be used to upload new firmware to the battery charger. For information on performing a firmware upgrade on the Raum4000b refer to the Firmware Upgrade section (page 37).

Generator Brake

The Raum4000b has a built in generator brake controller that automatically engages an external generator brake in severe weather conditions. (See the Installation chapter for correct hook up of the generator brake.) The brake simply enables or disables the generator; it does not provide stall control. The control lines are compatible with an external 12 V brake system like the one included inside the Raum 3.5kW generator. When engaged, 12 V power is cut from the brake control lines which automatically applies the brake. When disengaged, 12 V power is applied which disengages the brake.

Maintenance

General



WARNING – Never disassemble or modify the Raum4000b battery charger. There are no user serviceable parts inside.

1. Clean the heat sink from time to time by blowing compressed air in behind the battery charger.
2. Inspect the system occasionally for signs of damage to supply cables, conduits, switches and mounting hardware.
3. Test the generator brake once a year on a very windy day.
4. See your wind generator or PV manual for additional notes on maintenance.

Firmware Upgrade

To upgrade the Raum4000b firmware, do the following:

1. Insert a USB drive containing the updated firmware package file.
2. Navigate to Main Menu →Advanced→Software Update
3. Press the Enter button (⏏) to perform the update.

The Raum4000b will try to find an update on the inserted USB drive. If an update is found, the update will take approximately 7 minutes. It is VERY important that the unit not be powered down during this time. For the last 2 minutes of the update, the screen will be blank. Once the update is complete, the unit will show the Raum Energy logo, followed by the Main Menu. If the display remains blank after 10 minutes or the Raum Energy logo doesn't go away for 10 minutes, try disconnecting and reconnecting power to the battery charger. If normal operation doesn't resume within 30 minutes, the device may need service.

Troubleshooting



WARNING – The Raum4000b battery charger does not contain any user serviceable parts. Any attempt to disassemble, service, or modify a Raum4000b battery charger is accompanied by risks of electric shock, burn, fire, and equipment damage.



WARNING – Never disconnect the battery charger from the batteries when the turbine is spinning. Always ensure the turbine brake is enabled and the turbine has stopped before disconnecting the battery charger from the batteries. Failure to do so will result in damage to the battery charger.

If the Raum4000b battery charger reports frequent, consistent, repeatable or sporadic fault conditions, the system may be in need of repair. Engage the generator brake, then flip the DC-disconnect to the disconnected position. Note down the circumstances surrounding the error including: the time(s), weather conditions, error codes, behaviour of the Raum4000b battery charger front panel indicators and other signs of abnormality that may be of assistance to Customer Service.

How the Raum4000b Handles Faults

Generator/PV-side Faults !

Certain external events may cause the input voltage of the Raum4000b battery charger to rise beyond the limits of its subcomponents. In such an event the battery charger will halt the export of power and immediately activate the generator brake in an effort to protect itself. If this fails to stop the input voltage from rising, or in the case of PV inputs, a secondary safety system disengages the battery charger completely from the input source by means of a safety relay. In the event that the safety relay disconnects the battery charger from the turbine, the exclamation light will be illuminated and the error message

“Over Voltage” will be displayed in the Status menu. The power will need to be cycled before the battery charger resumes normal operation. To power cycle the battery charger first engage the turbine brake, then flip the DC-disconnect to disconnected position and wait for 30 seconds before flipping it back to the connected position.

Internal Faults

The Raum4000b battery charger is an electrical machine that is robust and intelligent; internal power circuits can withstand unforgiving electrical conditions by design and are monitored by the system controller. The watchdog role of the system controller extends to faults in the control system itself. All systems are monitored for unlikely conditions that may compromise the reliability of operation. In such an event the controller will interrupt all systems, light the System Error indicator on the user interface panel, display an internal error code and wait for the fault to clear. Once the fault has cleared, the controller will monitor the system for a period of time before renegotiating power export. During this period the Error LED will blink while the error code remains as a status display. If, however, normal operation does not commence due to a persistent fault condition, the Error LED will remain on.

Q&A

Having Trouble Navigating the Menu?

Customer Service can assist with Front Panel issues and Web site details but not network administration.

“Output Fuse” Error Persists on Screen?

Check that the battery system voltage is set to the appropriate setting for the battery bank in use – this can be done in the Batt Config menu (page 31). If the appropriate system voltage is selected and the problem persists please contact your Dealer.

System Doesn't Export Power?

If the system is new and is yet to show signs of life, double check to make sure all attributes of the installation were completed correctly. Are the connection wires at the battery charger stripped back far enough to make contact in the terminal blocks? Has the generator brake been forgotten on accidentally? Check if the PV connection isn't backwards. Make sure the battery system voltage is set correctly. (The Raum4000b is factory preset for 24V as labelled on the side of the enclosure.)

Customer Service

For technical assistance, repair or replacement warranty services we recommend you contact your dealer first (see your notes on page 5). If directed to the manufacturer, contact:

Raum Energy Inc.
3718A Millar Avenue
Saskatoon, SK, S7P 0B1
Canada

P: (306) 651-0586

F: (306) 651-0605

WWW.RAUMENERGY.COM

Warranty Information

Subject to the terms and conditions of this Warranty, Raum Energy Inc. warrants the original purchaser only, that under normal usage the Raum4000b battery charger will substantially conform with the user manual performance for a period of 24 months starting as of the date of your sales receipt ("the WARRANTY PERIOD"). As to any defects discovered after the Warranty Period, there is no warranty or condition of any kind. Any tampering with the Raum4000b battery charger by unauthorized personnel will void this warranty. In addition, this warranty does not cover malfunctions, cosmetic or functional, due to damage or improper installation.

Appendix A: Technical Description

The energy conversion process of the Raum4000b Battery Charger is described in part by the system block diagram in Figure 15. The wind generator produces 3-phase AC power which is first rectified to an unregulated DC state. The unregulated DC voltage then proceeds through two stages. The first stage is a high voltage buck (or switching) regulator which efficiently converts high voltage DC into an intermediate DC voltage level. The second stage is a low voltage buck (or switching) regulator which converts the intermediate DC voltage into a stable battery voltage. The two stage process allows for a very wide range of input voltages (up to 450 volts DC on the input).

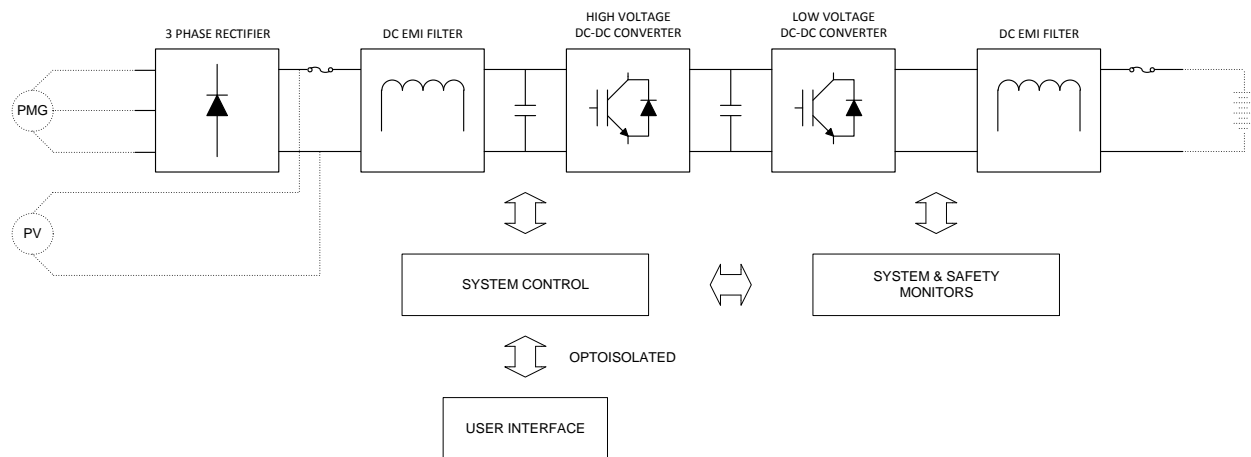

Figure 15 - Battery charger block diagram. Dotted areas are external to the battery charger.

Appendix B: Raum4000b Unit Ratings

Table 1 – Raum4000b Battery Charger Performance Ratings

| | |
|---|---|
| Max PV/Turbine Source Voltage | 600 V _{DC} / 444 V _{RMS, L-L} |
| PV/Turbine Operating Source Voltage | 60...450 V _{DC} / 45...333 V _{RMS, L-L} |
| Max PV/Turbine Source Operating Current | 20 A _{DC} / 15.6 A _{RMS, L-L} |
| Max PV/Turbine Source Short-Circuit Current | 30 A _{DC} / 23.4 A _{RMS, L-L} |
| Max Continuous Output Power | 3800 W |
| Max Continuous Output Current | 145 A _{DC} |
| Max Output Fault Current | 210 A _{DC} |
| Nominal Output (Battery) Voltages | 24 V _{DC} / 48 V _{DC} |
| Max Output (Battery) Voltage | 70 V _{DC} |
| Max Dump Load Voltage | 70 V _{DC} / 120 V _{AC} |
| Max Dump Load Current | 20 A _{DC} / 12.5 A _{AC} |
| Max Ambient Operating Temperature | 40 °C / 104 °F |
| Enclosure | NEMA 4: Watertight / IP65 |
| Size | 52 cm x 30.6 cm x 15.9 cm (20.5" x 12" x 6.25") |
| Mass | 20.4 kg (45 lb) |
| Relative Humidity | 0 - 100% Condensation Point |
| Maximum Operating Altitude Above Sea Level | 2000 m |

Appendix C: Battery Charge States



WARNING – The following settings and information are recommendations for informative purposes only. Check with your battery manufacturer for correct charging and voltage settings. Failure to do so may result in damage or failure of the battery bank.

The charge level of a battery can be determined by its voltage level, commonly referred to as the battery state of charge. The battery state of charge is a measure of the amount of energy stored in the battery at any given time. Typical lead acid batteries consist of series strings of 2 volt cells, whereby the most common configuration is a 6 cell configuration making up a 12 volt battery. A fully charged a 2 volt cell will have a voltage of 2.4 volts (indicating a completely charged state – 100% state of charge); meanwhile, a fully discharged 2 volt cell will have a voltage of approximately 1.9 volts (fully discharged). Table 2 shows the battery state of charge levels for the most common battery voltages.

Table 2 – Battery State of Charge Chart for Common Battery Voltages

| Nominal Battery Voltage (Volts) | Battery State of Charge (Volts) | | | | |
|---------------------------------|---------------------------------|-------------|----------------|------------|------------|
| | Charged | Good (~75%) | Average (~50%) | Low (~25%) | Discharged |
| 24 | > 25.3 | 24.9 | 24.5 | 24.12 | < 23.8 |
| 48 | >50.6 | 49.8 | 49.8 | 48.24 | < 47.6 |

Operating a battery below 50% state of charge for long periods of time can affect the long term health of a battery and can result in premature failure of the battery.

The Raum4000b Battery Charger is an intelligent multi-stage battery charging system that employs several charging methods to allow fast charging and ensure long battery life. There are three basic stages involved in efficiently charging a lead acid battery. The first stage applies a constant current to raise the battery voltage to some preset limit. Once that preset voltage limit is reached the battery enters stage two where the preset voltage is fixed and the charge current gradually decreases until it reaches approximately 3% of the rated current. These first two stages make up a complete absorb stage. Lastly, the third stage involves float charging the battery to compensate for self-discharge.

Correct settings of the voltage limits are critical for long term battery life. For stage one of the charge cycle the voltage limit is a compromise between obtaining maximum capacity

and avoiding a continually over-saturated condition. This upper voltage limit is referred to as the *Abs (Absorb) Voltage* and most battery manufacturers recommend a setting of 2.30 volts – 2.45 volts per cell. The battery cannot remain at peak voltage for too long. After reaching full charge the voltage must be reduced to maintain the battery voltage between 2.25 volts and 2.27 volts per cell. This lower voltage limit is referred to as the *Float Voltage*. Table 3 contains a table of recommended set points for both the *Abs Voltage* as well as the *Float Voltage* of the most common system voltages.

From time to time it may be required that the battery voltage be raised above the *Abs Voltage* in order to equalize all of the individual 2 volt cells to the same voltage. It is important to consult the manufacturer specifications when initiating an equalization charge to ensure no long term damage is done to the batteries. The factory default equalization voltage (*Equ Voltage*) for the Raum4000b Battery Charger is the same as the factory default absorb voltage (*Abs Voltage*).

Table 3 – Recommended Battery Voltage Set Points (Default Voltage Set Points for Raum4000b)

| Nominal Battery Voltage (Volts) | Voltage Set Point (Volts) | | |
|---------------------------------|---------------------------|---------------|---------------------|
| | Float Charge | Absorb Charge | Equalization Charge |
| 24 | 27.0 | 28.8 | 28.8 |
| 48 | 54.0 | 57.6 | 57.6 |