

Raum Energy Inc. 15m Lattice Tower Foundation Construction Guide

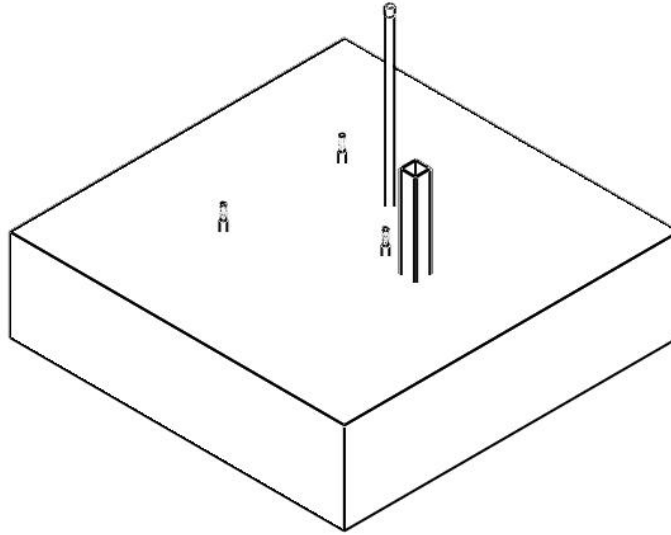

Raum Energy Inc.
3718A Millar Ave. N
Saskatoon, SK
S7P 0B1

PH: (306) 651-0586

WARNING!

The foundation construction guidelines contained herein is a result of careful design and consideration. Raum Energy Inc. will not warrantee any foundation installed by the customer in contradiction of these guidelines. In addition, Raum Energy is not liable for any damage to the Raum Energy wind turbine system or any collateral damage as a result of a faulty or defective foundation installation.

IMPORTANT!

Read this manual entirely before you start. Failure to accurately follow these steps may result in a foundation that cannot be used for a tower installation.

Digging and installing rebar can be a physically strenuous activity and should only be performed by a person (or people) in good health in good weather conditions.

This foundation has been designed to meet the National Building Code wind loads for Saskatchewan specifically for the 15 meter tower and Raum Energy 1.5kW wind turbine. This foundation does not apply to other towers or to other wind turbines.

This foundation was designed with the following notes and assumptions:

- there is no seismic activity in the area
- the foundation is not impinging on bedrock
- the foundation is not cast on organic or loose soil
- maximum wind loading is designed for Saskatchewan, areas of higher wind require additional design by a structural engineer
- concrete to be minimum 25MPa (28 day strength) and to be sulphate resistant
- use type 50 cement

Raum Energy recommends that you consult a qualified structural engineer concerning specific requirements for your tower location.

Be sure to call all local utilities to insure you will not damage underground gas, power, or phone lines.

Before you start:

Before you start to dig the foundation, you must consider the location that the tower will be installed. Make sure that the foundation is at least 25m (82') which is 1.5 times tower heights from any overhead power lines, trees or structures. Be sure to consult your local utility for specific easements from nearby overhead power lines.

The tower pivots at the bottom to raise and lower the tower so there must be at least 60' of clear space in one direction and 100' of clear space in the opposite direction for the vehicle or winch which will be lifting the tower.

Assuming that you are digging the foundation by hand, preparing the foundation for the concrete pour will take approximately 10 person-hours of time. Care should be taken to have the site ready for concrete well before the concrete arrives on site.

Tools required:

Shovel or excavation equipment for digging 2 feet deep into soil
Rebar cutter
Rebar tie-wire
Wire cutters
Pliers
Electric drill
1" diameter wood drill bit
1 ½" diameter wood drill bit
Sabre saw or small circular saw
Hammer
Spirit level

Material required:

- (1) Grounding kit
- (3) Tower anchors (Anchor bolts) and
- (6) 1" jam nuts
- (1) 4" x 4" x 0.065" wall 4' long square steel tubing
- (1) 1" plastic conduit with 90° elbow on one end, minimum 72" long
- (6) 2" X 4" X 10' wood
- (1) 2" X 8" X 42" wood
- (2) 5/8" Plywood Anchor patterns
- (28) 7' (2.34m) 15M Rebar
- (2) 5/8" Plywood sheet
- 1 ½" nails

Tower anchor:



Plastic conduit: 1" conduit with a 90° elbow as shown in the following image.

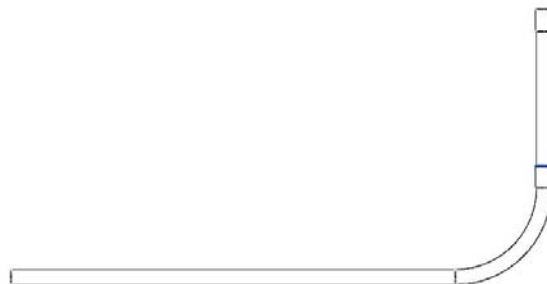

Plywood anchor pattern:

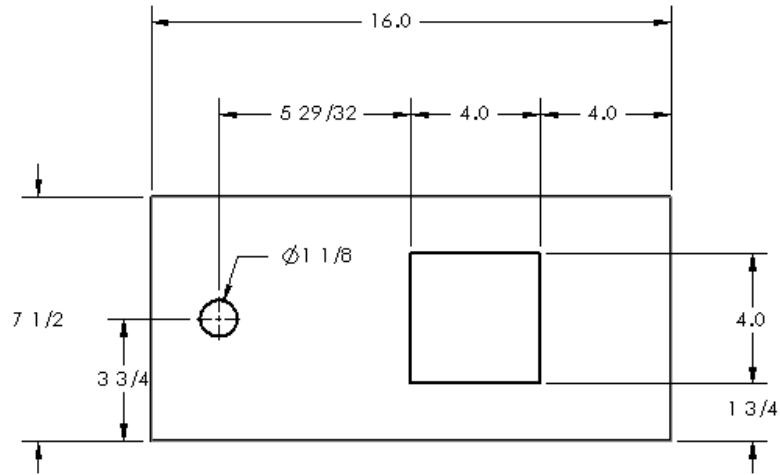

2 X 8 Pattern

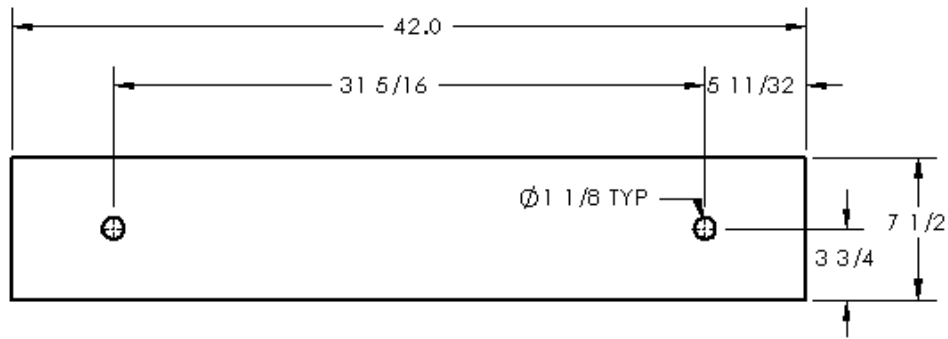

Foundation Construction

Step 1: Using 5/8" plywood and 7'4" lengths of 2" X 4", build 2 forms for bracing the foundation. Suggested dimensions of the forms are shown. The forms will be used to contain the concrete in the pit.

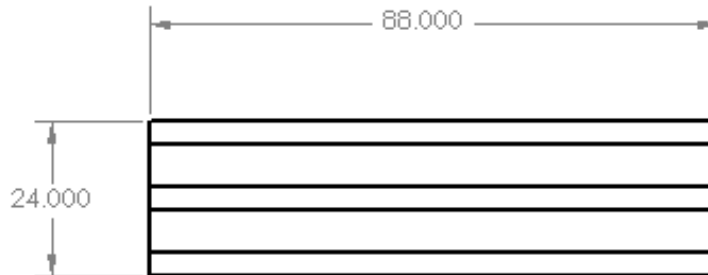

Step 2: Dig a 7'4" X 7'4" X 2' hole. Be sure to get below organic level on well drained undisturbed subsoil.

Step 3: Construct a frame around the outer edge of the hole using the 10' pieces of 2 X 4. On two opposite sides, place the forms in the hole. The distance between the forms should be 7'4". The concrete will pour right up to the top of this frame, level appropriately.

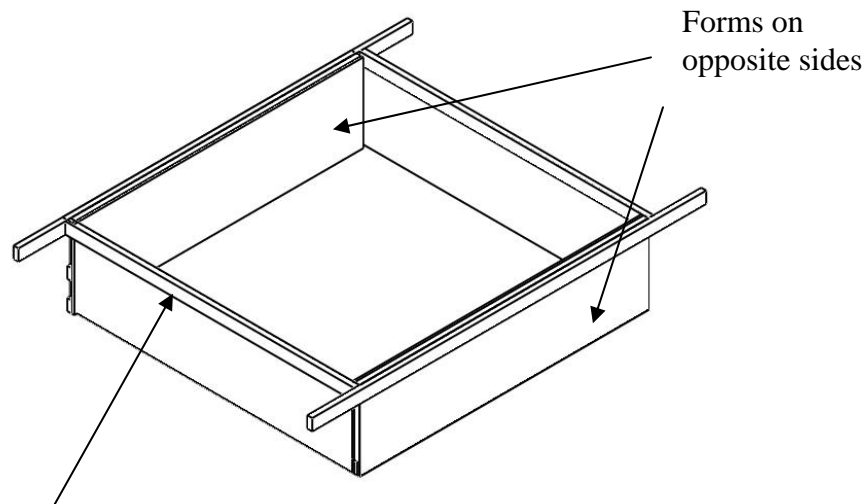

2 X 4 Frame around outside of hole, Concrete to pour right to the top surface of 2 X 4

Step 4: Build two rebar grids from the 7' 15M rebar pieces and place in the hole. Grid dimensions are shown below. Use rebar ties to secure every intersection of rebar.

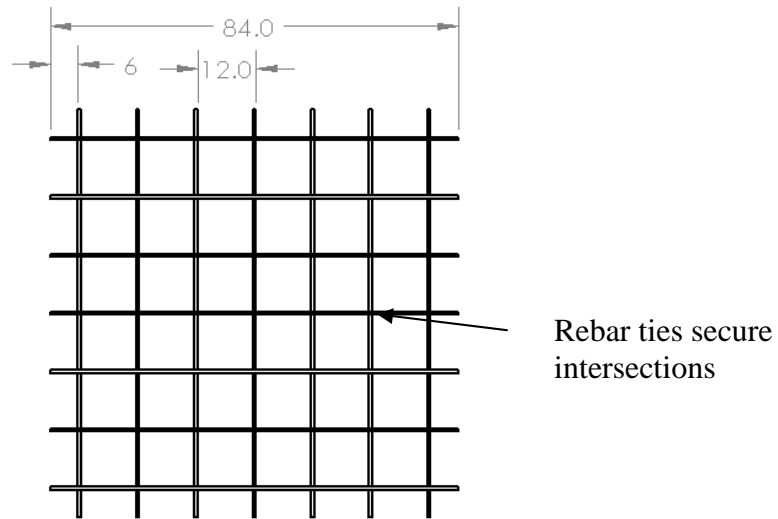

Step 5: Hammer 4 stakes into the ground on the outside of the hole. Stakes should be placed as shown. Use the stakes to level two 10' 2 X 4s across the hole. The 2 X 4s should be no more than 1/4" above the frame surrounding the hole, if the frame is level the 2 X 4's may rest on it. Place the plywood anchor pattern and 2 X 8 as shown. **The holes must be spaced correctly in order to place the tower on the foundation.** Place another 2 X 4 to locate the PVC Conduit, Conduit must be outside of tower triangle, but close enough to where it can be supported by the tower.

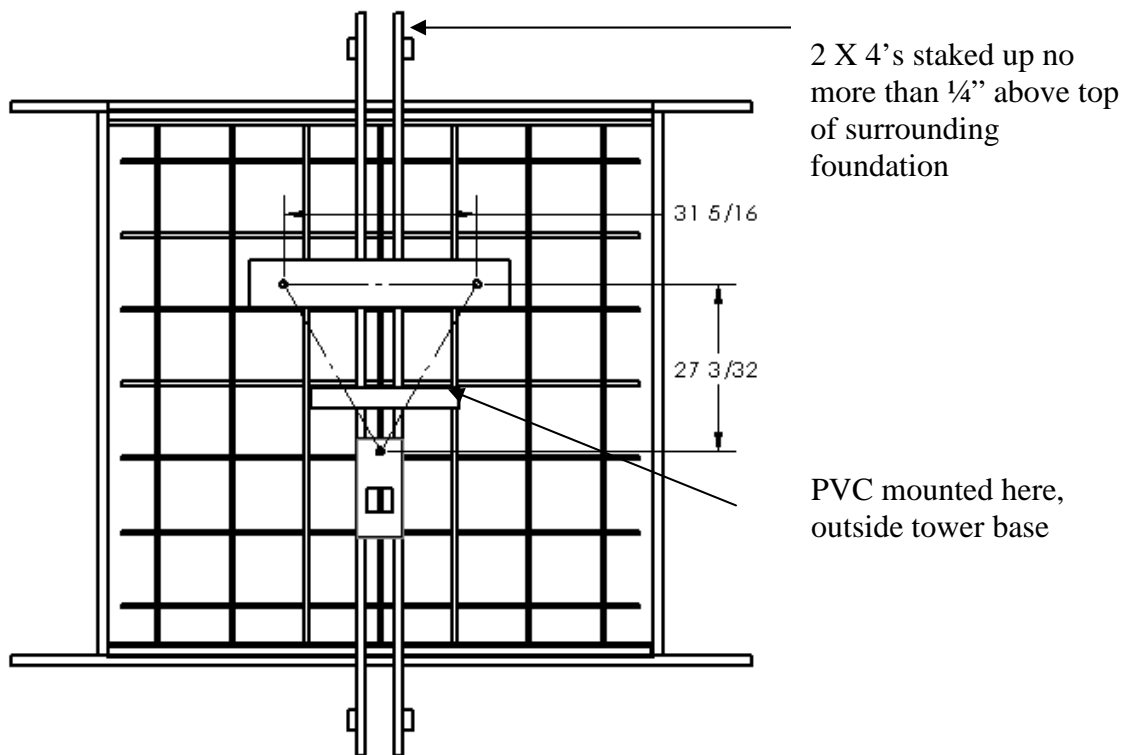

Step 6: Hang the rebar either using rebar ties or anchors. The bottom rebar grid should be placed 3” above the bottom of the hole, while the second rebar grid should be placed 3” from the top of the hole

Step 7: Place the tower anchors through each of the 3 – 1” cut outs on the plywood template, so that the threaded end of the anchors protrudes not more than 6” (0.15m) from the top of the concrete. Engage and tighten the 1” jam nuts onto the tower anchors, 1 jam nut is placed below the plywood and one on top. The other end of the anchors are tied to the rebar using rebar wire to ensure they do not move during the concrete pour, also ensure that the toes of the anchors are POINTED OUTWARDS.

Tower anchors, jam nut top and bottom of plywood, foot pointed out, no more than 6” above concrete

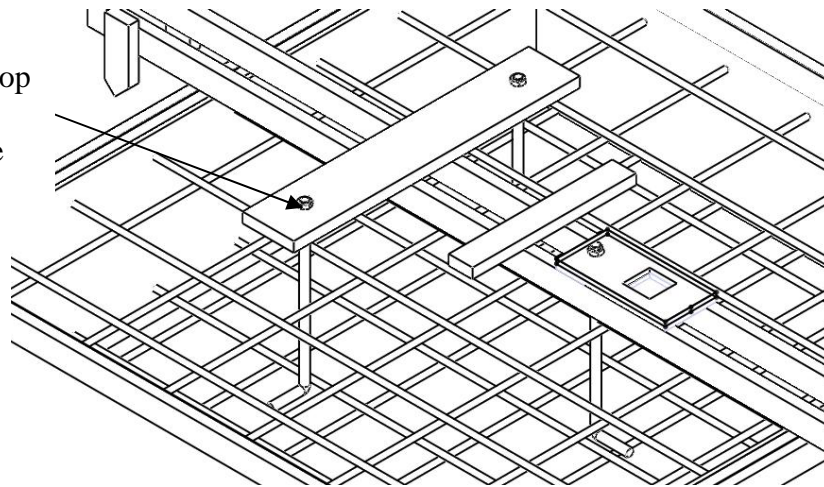

Step 8: Place the conduit in a location that’s 12” outside the perimeter of the triangle. You may have to use additional wood to accomplish this. The conduit should protrude 5’ above the top of the concrete foundation. Push the end of the conduit into dirt surrounding the foundation at the location which you would like the TEK cable to leave the turbine foundation. You will dig this out later when running the wire so make sure no concrete gets into the conduit (duct tape the ends). Also place the steel 4 X 4 tube in the plywood anchor cutout, this will extrude 2’ from the top of the concrete.

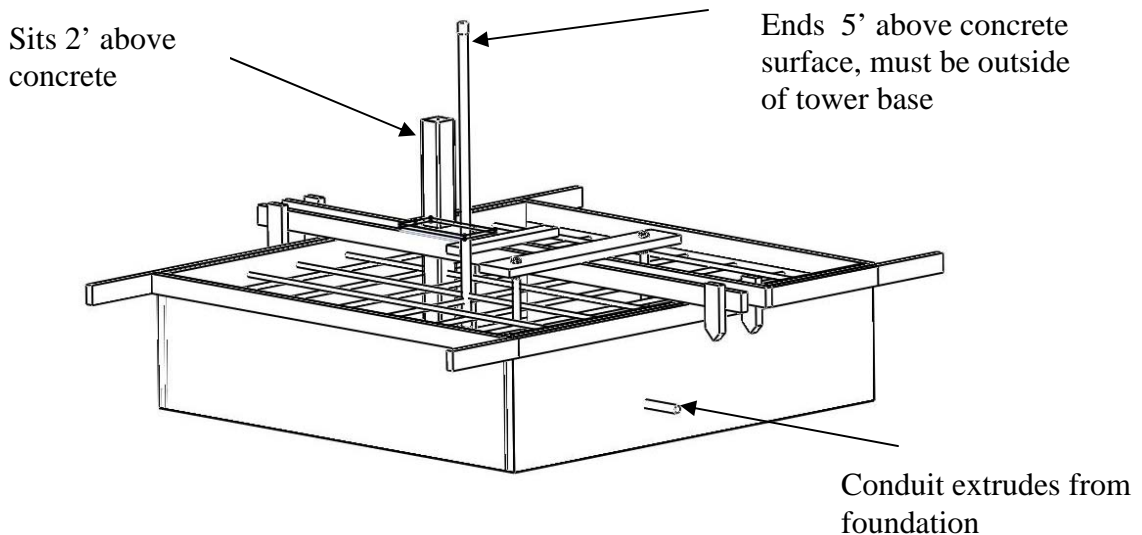

Step 9: Place the grounding plate on the ground in the bottom of the foundation pit. Attach the grounding clamp to the plate and to one of the tower legs with the short copper wire strip (#6 copper braided minimum). Note that the Electrical Inspector may request to inspect the grounding method BEFORE concrete is poured.

Ground Plate to be tied to Anchor bolt with copper wire

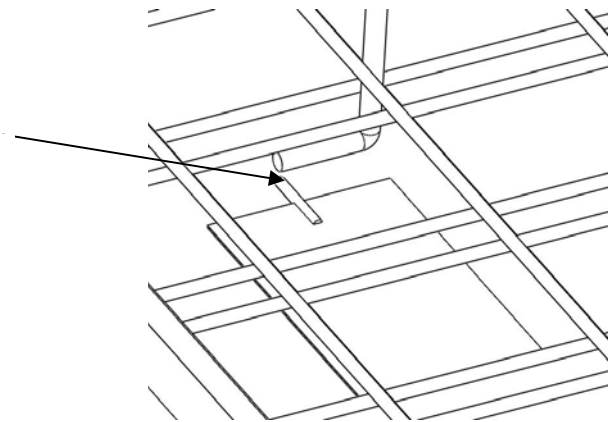

Step 10: Carefully pour the concrete into the foundation pit. Ensure that the three tower legs have remained vertical and that the conduit has remained in the proper position.

Step 11: Wait for the concrete to dry. Then remove the three jam nuts from the tower legs and remove the plywood template. Remove all of the forms and wood frames used in construction.

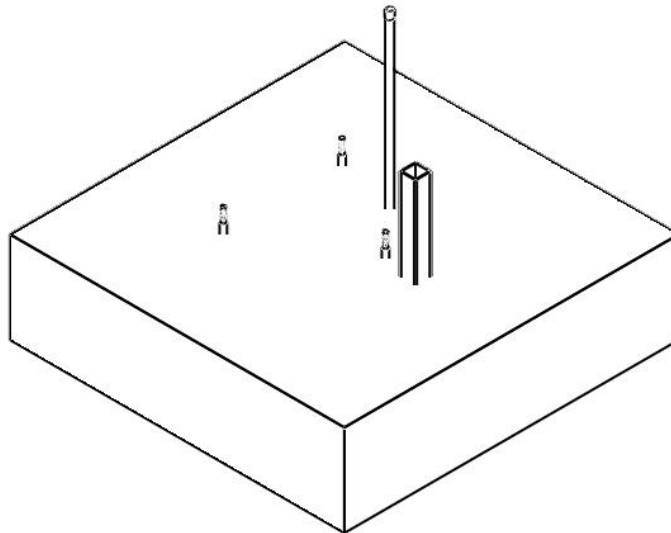

WARNING: Do not erect the turbine tower for a minimum of 21 days after the pour. Beware that cold weather conditions may require a longer interval.

Appendix

Cabling Requirements:

The path of the TEK cable that connects the wind turbine to the grid-tie inverter is shown below. Therefore, the TEK output must be within 48" of the target service panel. Minimum wire gauge is 14, and the most common used is 12 gauge. For more information, consult a qualified electrician or the Canadian Electrical Code.

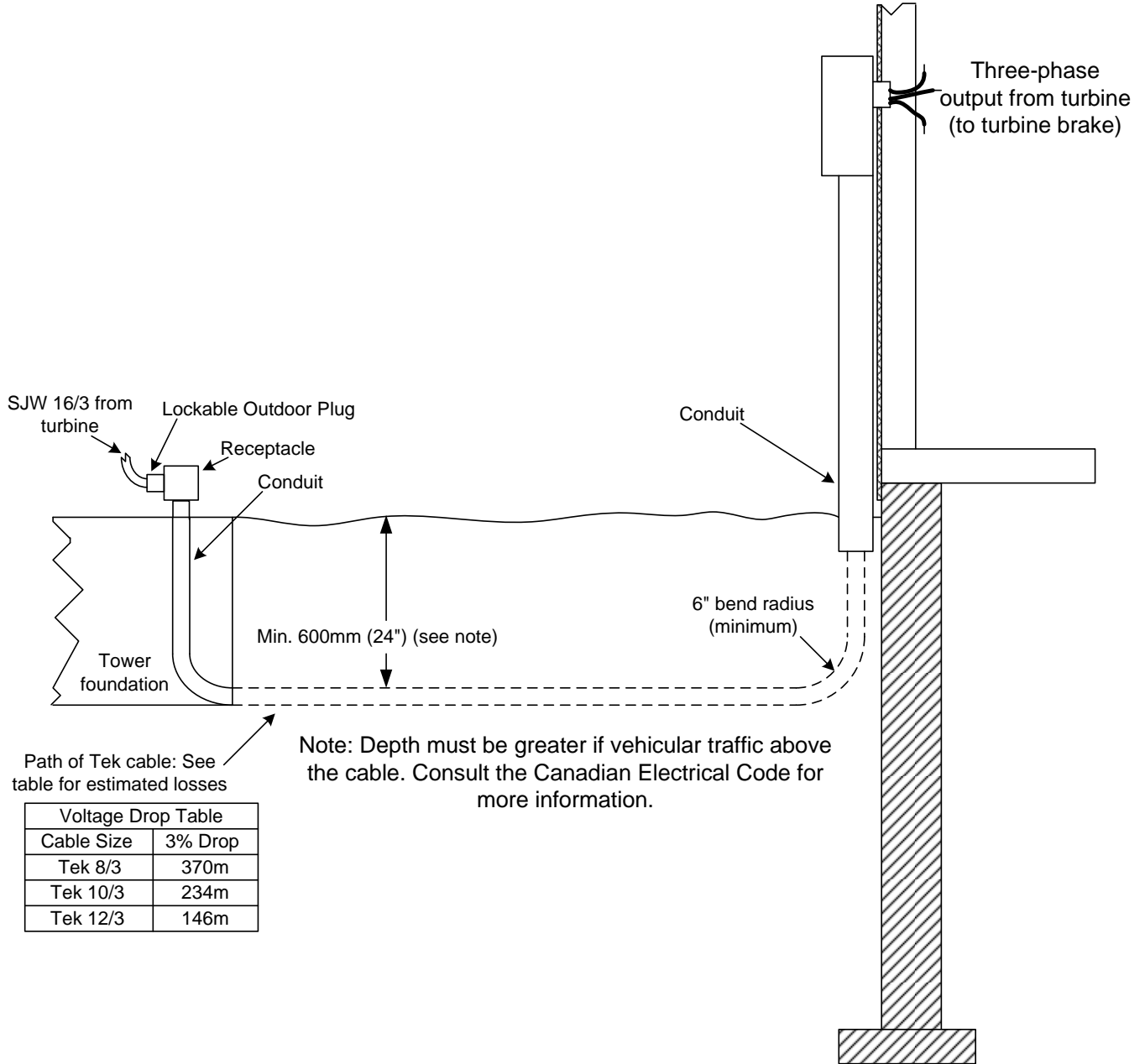

Path of Tek cable: See table for estimated losses

Voltage Drop Table	
Cable Size	3% Drop
Tek 8/3	370m
Tek 10/3	234m
Tek 12/3	146m

Typical Installation

The diagram below is a typical installation for most utilities. Please check with your local utility on any additional requirements that may be required.

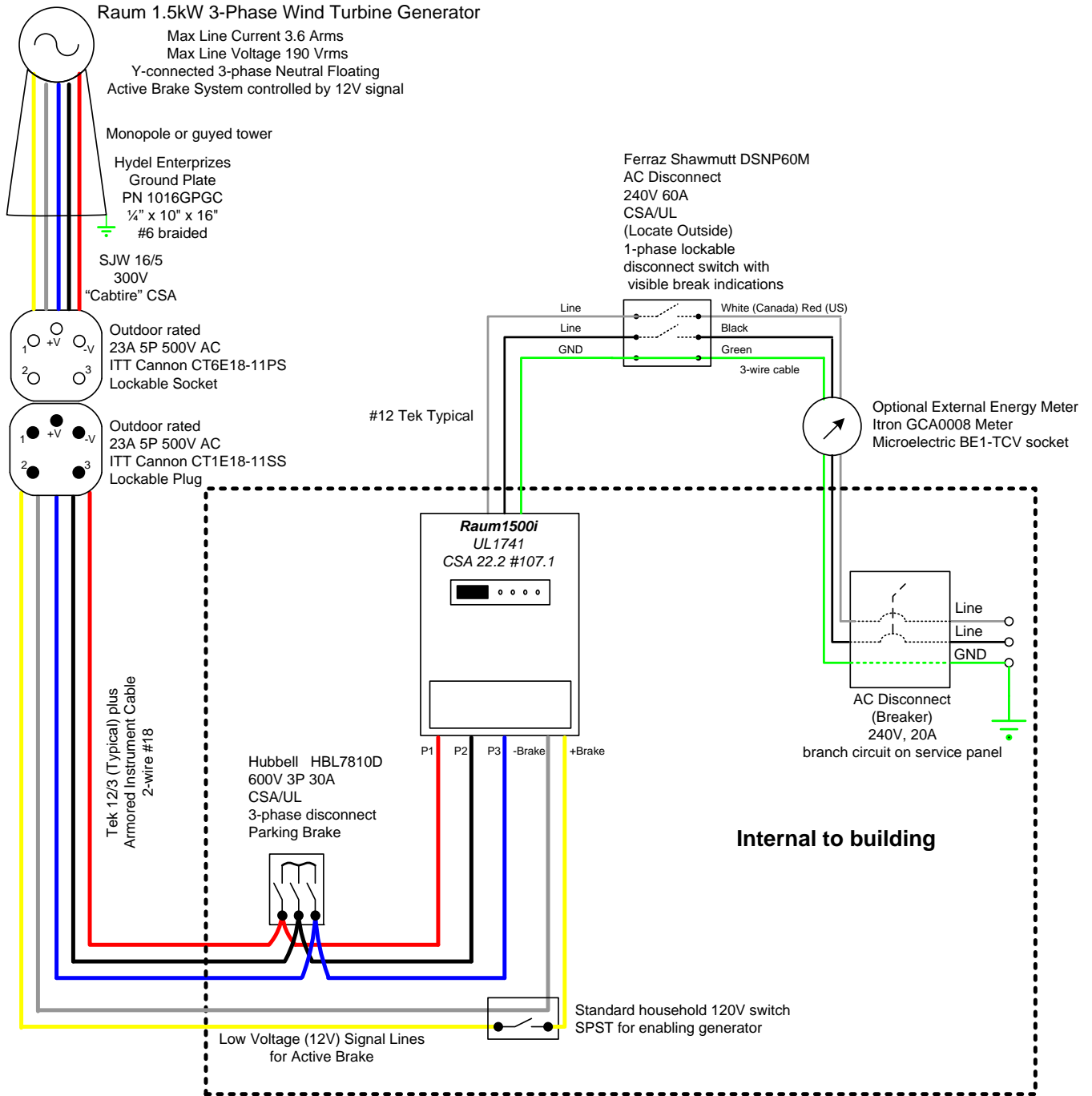

All Raam Energy products are engineered to meet or exceed CSA and Canadian Electrical Code standards.